

Octal channel high side driver

Features

| Type | $R_{DS(on)}^{(1)}$ | $I_{out}^{(1)}$ | V_{CC} |
|---------|--------------------|-----------------|----------|
| VN808-E | 150 mΩ | 0.7 A | 45 V |

1. Per channel

- $V_{CC}/2$ compatible input
- Junction over-temperature protection
- Case over-temperature protection for thermal independence of the channels
- Current limitation
- Shorted load protection
- Undervoltage shut-down
- Protection against loss of ground
- Very low stand-by current
- Compliance to 61000-4-4 IEC test up to 4 kV

Description

The VN808-E is a monolithic device designed in STMicroelectronics VIPower M0-3 technology, intended for driving any kind of load with one side connected to ground.

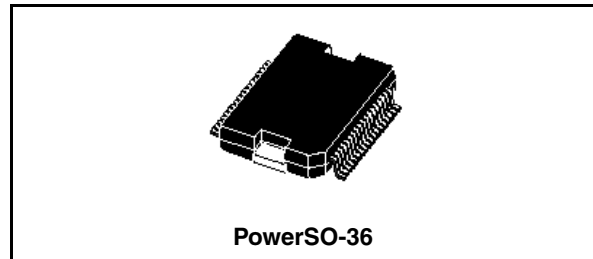

Active current limitation combined with thermal shutdown and automatic restart, protect the device against overload. In overload condition, channel turns OFF and back ON automatically so as to maintain junction temperature between T_{TSD} and T_R . If this condition makes case temperature reach T_{CSD} , overloaded channel is turned OFF and will restart only when case temperature has decreased down to T_{CR} (see waveform 3 [Figure 8 on page 11](#)). Non overloaded channels continue to operate normally. Device automatically turns OFF in case of ground pin disconnection. This device is especially suitable for industrial applications conform to IEC 61131

Figure 1. Block diagram

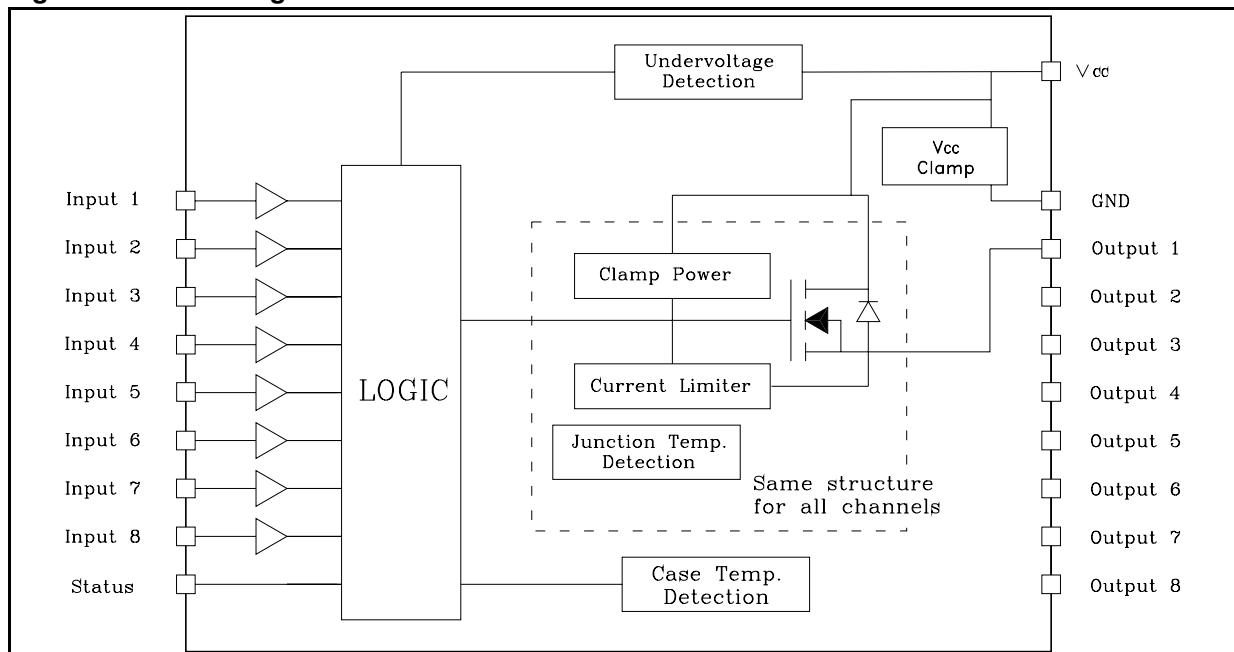

Contents

| | | |
|---|---|----|
| 1 | Maximum ratings | 3 |
| 2 | Electrical characteristics | 4 |
| 3 | Pin connections | 6 |
| 4 | Current, voltage conventions and internal diagram | 8 |
| 5 | Switching time waveforms | 10 |
| 6 | Reverse polarity protection | 13 |
| 7 | Package mechanical data | 14 |
| 8 | Order codes | 16 |
| 9 | Revision history | 17 |

1 Maximum ratings

Table 1. Absolute maximum rating

| Symbol | Parameter | Value | Unit |
|------------|--|--------------------|------------------|
| V_{CC} | DC supply voltage | 45 | V |
| $-I_{GND}$ | DC ground pin reverse current TRAN ground pin reverse current (pulse duration < 1ms) | -250 -6 | mA A |
| I_{OUT} | DC output current | Internally limited | A |
| $-I_{OUT}$ | Reverse DC output current | -2 | A |
| I_{IN} | DC input current | ± 10 | mA |
| V_{IN} | Input voltage range | $-3/+V_{CC}$ | V |
| V_{ESD} | Electrostatic discharge (R = 1.5 k Ω ; C = 100 pF) | 2000 | V |
| P_{TOT} | Power dissipation at $T_C = 25\text{ }^\circ\text{C}$ | 96 | W |
| L_{MAX} | Max inductive load ($V_{CC} = 24\text{ V}$, $R_{LOAD} = 48\text{ }\Omega$, $T_A = 100\text{ }^\circ\text{C}$) | 2 | H |
| T_J | Junction operating temperature | Internally limited | $^\circ\text{C}$ |
| T_C | Case operating temperature | Internally limited | $^\circ\text{C}$ |
| T_{STG} | Storage temperature | -40 to 150 | $^\circ\text{C}$ |

Table 2. Thermal data

| Symbol | Parameter | Value | Unit |
|------------|--|---------|---------------------------|
| R_{thJC} | Thermal resistance junction-case | Max 1.3 | $^\circ\text{C}/\text{W}$ |
| R_{thJA} | Thermal resistance junction-ambient ⁽¹⁾ | Max 50 | $^\circ\text{C}/\text{W}$ |

1. When mounted on FR4 printed circuit board with 0.5 cm² of copper area (at least 35 μm thick) connected to all TAB pins.

2 Electrical characteristics

(10.5 V < V_{CC} < 32 V; -40 °C < T_J < 125 °C; unless otherwise specified)

Table 3. Power section

| Symbol | Parameter | Test conditions | Min | Typ | Max | Unit |
|-----------------------------------|--|--|------|-----|------------|----------|
| V _{CC} | Operating supply voltage | | 10.5 | | 45 | V |
| V _{USD} | Undervoltage shutdown | | 7 | | 10.5 | V |
| R _{ON} | On state resistance | I _{OUT} = 0.5 A; T _J = 25 °C I _{OUT} = 0.5 A; | | 150 | 185 280 | mΩ mΩ |
| I _S | Supply current | OFF state; V _{CC} = 24 V; T _{CASE} = 25 °C ON state (all channels ON); V _{CC} = 24 V, T _{CASE} = 100 °C | | | 150 12 | μA mA |
| I _{LGND} | Output current at turn-off | V _{CC} = V _{STAT} = V _{IN} = V _{GND} = 24 V V _{OUT} = 0 V | | | 1 | mA |
| I _{L(off)} | OFF state output current | V _{IN} = V _{OUT} = 0 V; | 0 | | 5 | μA |
| V _{OUT(off)} | OFF state output voltage | V _{IN} = 0 V, I _{OUT} = 0 A | | | 3 | V |
| t _{d(V_{CC}con)} | Power-on delay time from V _{CC} rising edge | <i>Figure 7 on page 10</i> | | 1 | | ms |

Table 4. Switching (V_{CC} = 24 V)

| Symbol | Parameter | Test conditions | Min | Typ | Max | Unit |
|--|------------------------|--|-----|-----|-----|------|
| t _{ON} | Turn-on time | R _L = 48 Ω from 80 % V _{OUT} <i>Figure 6.</i> | | 50 | 100 | μs |
| t _{OFF} | Turn-off time | R _L = 48 Ω to 10 % V _{OUT} <i>Figure 6.</i> | | 75 | 150 | μs |
| dV _{OUT} /dt _(on) | Turn-on voltage slope | R _L = 48 Ω from V _{OUT} = 2.4 V to V _{OUT} = 19.2 V <i>Figure 6.</i> | | 0.7 | | V/μs |
| dV _{OUT} /dt _(off) | Turn-off voltage slope | R _L = 48 Ω from V _{OUT} = 21.6 V to V _{OUT} = 2.4 V <i>Figure 6.</i> | | 1.5 | | V/μs |

Table 5. Input pin

| Symbol | Parameter | Test conditions | Min | Typ | Max | Unit |
|---------------|--------------------------|---------------------------|--------------|-----|--------------|---------|
| V_{INL} | Input low level | | | | $V_{CC}/2-1$ | V |
| I_{INL} | Low level input current | $V_{IN} = V_{CC}/2 - 1$ V | 80 | | | μ A |
| V_{INH} | Input high level | | $V_{CC}/2+1$ | | | V |
| I_{INH} | High level input current | $V_{IN} = V_{CC}/2 + 1$ V | | 150 | 260 | μ A |
| $V_{I(HYST)}$ | Input hysteresis voltage | | | 0.6 | | V |
| I_{IN} | Input current | $V_{IN} = V_{CC} = 32$ V | | | 300 | μ A |

Table 6. Protections

| Symbol | Parameter | Test conditions | Min | Typ | Max | Unit |
|-------------|--------------------------------------|---|-------------|-------------|-------------|--------------|
| T_{CSD} | Case shut-down temperature | | 125 | 130 | 135 | $^{\circ}$ C |
| T_{CR} | Case reset temperature | | 110 | | | $^{\circ}$ C |
| T_{CHYST} | Case thermal hysteresis | | 7 | 15 | | $^{\circ}$ C |
| T_{TSD} | Junction shutdown temperature | | 150 | 175 | 200 | $^{\circ}$ C |
| T_R | Junction reset temperature | | 135 | | | $^{\circ}$ C |
| T_{HYST} | Junction thermal hysteresis | | 7 | 15 | | $^{\circ}$ C |
| I_{lim} | DC short circuit current per channel | $V_{CC} = 24$ V; $R_{LOAD} = 10$ m Ω | 0.7 | | 1.7 | A |
| V_{demag} | Turn-off output clamp voltage | $I_{OUT} = 0.5$ A; $L = 6$ mH | $V_{CC}-57$ | $V_{CC}-52$ | $V_{CC}-47$ | V |

Table 7. Status pin

| Symbol | Parameter | Test conditions | Min | Typ | Max | Unit |
|--------------|---------------------------|---|-----|-------------|-----|---------|
| I_{HSTAT} | High level output current | $V_{CC} = 18...32$ V; $R_{STAT} = 1$ k Ω (Fault condition) | 2 | 3 | 4 | mA |
| I_{LSTAT} | Leakage current | Normal operation; $V_{CC} = 32$ V | | | 0.1 | μ A |
| V_{CLSTAT} | Clamp voltage | $I_{STAT} = 1$ mA $I_{STAT} = -1$ mA | 6.0 | 6.8 -0.7 | 8.0 | V V |

3 Pin connections

Figure 2. Connection diagram (top view)

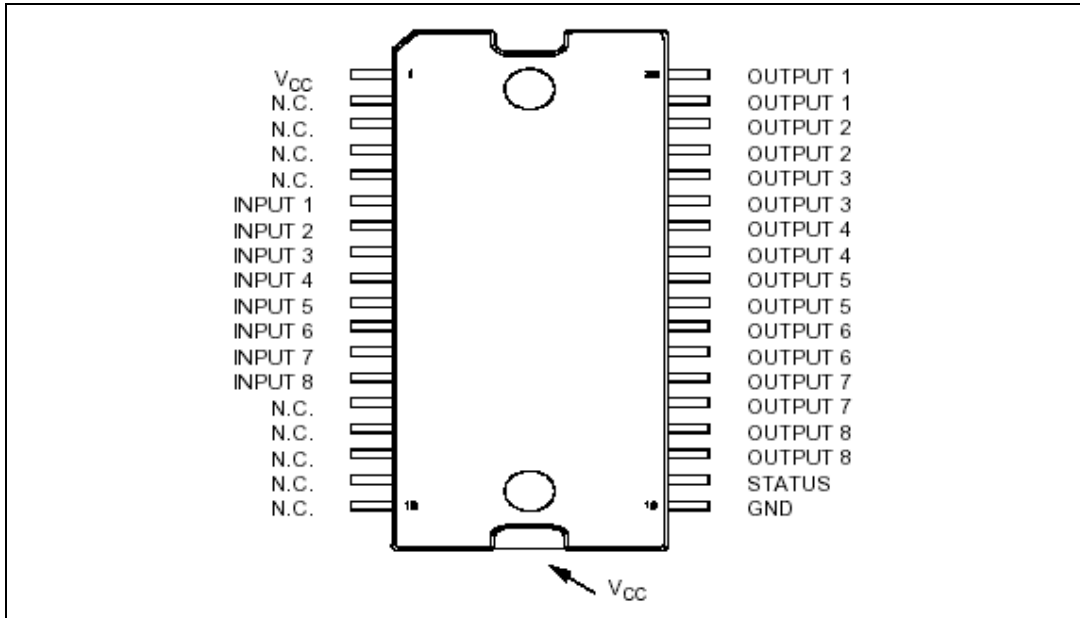

Table 8. Pin functions

| Pin N° | Symbol | Function |
|----------------|-----------------|--|
| TAB | V _{CC} | Positive power supply voltage |
| 1 | V _{CC} | Positive power supply voltage |
| 2,3,4,5 | NC | Not connected |
| 6 | Input 1 | Input of channel 1 |
| 7 | Input 2 | Input of channel 2 |
| 8 | Input 3 | Input of channel 3 |
| 9 | Input 4 | Input of channel 4 |
| 10 | Input 5 | Input of channel 5 |
| 11 | Input 6 | Input of channel 6 |
| 12 | Input 7 | Input of channel 7 |
| 13 | Input 8 | Input of channel 8 |
| 14,15,16,17,18 | NC | Not connected |
| 19 | GND | Logic ground |
| 20 | STATUS | Common open source diagnostic for over-temperature |
| 21,22 | Output 8 | High-side output of channel 8 |
| 23,24 | Output 7 | High-side output of channel 7 |

Table 8. Pin functions (continued)

| Pin N° | Symbol | Function |
|--------|----------|-------------------------------|
| 25, 26 | Output 6 | High-side output of channel 6 |
| 27, 28 | Output 5 | High-side output of channel 5 |
| 29, 30 | Output 4 | High-side output of channel 4 |
| 31, 32 | Output 3 | High-side output of channel 3 |
| 33, 34 | Output 2 | High-side output of channel 2 |
| 35, 36 | Output 1 | High-side output of channel 1 |

4 Current, voltage conventions and internal diagram

Figure 3. Current and voltage conventions

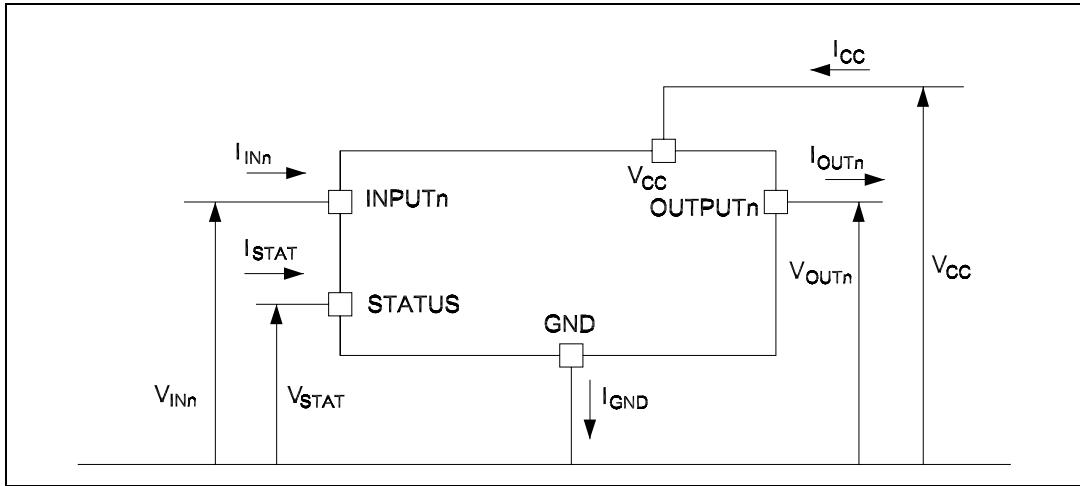

Figure 4. Equivalent internal block diagram (same structure for all channel)

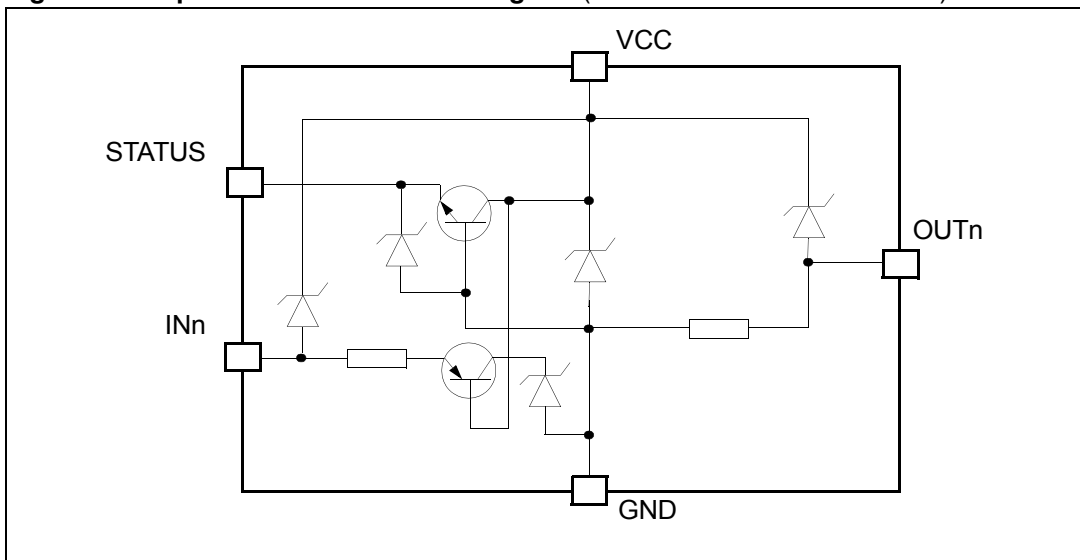

Figure 5. Application example

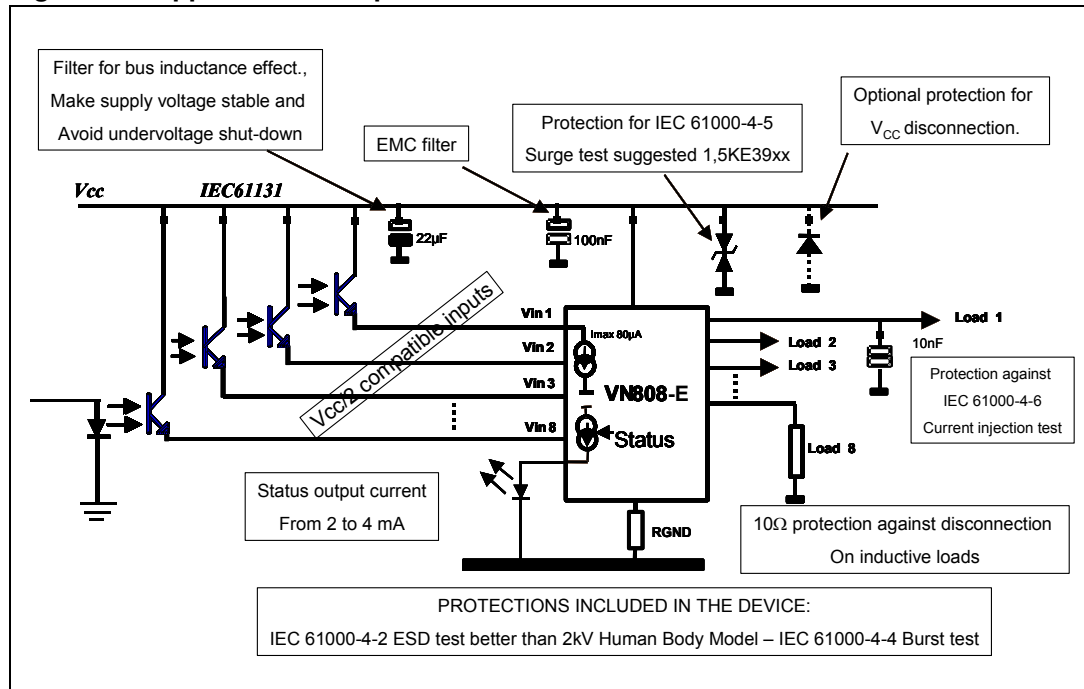

Table 9. Truth table

| Conditions | INPUTn | OUTPUTn | STATUS |
|--|--------|---------|--------|
| Normal operation | L H | L H | L L |
| Current limitation | L H | L X | L L |
| Overtemperature (see waveforms 3, 4 Figure 8) -> $T_J > T_{TSD}$ | L H | L L | L H |
| Undervoltage | L H | L L | X X |

5 Switching time waveforms

Figure 6. Turn-ON and turn-OFF

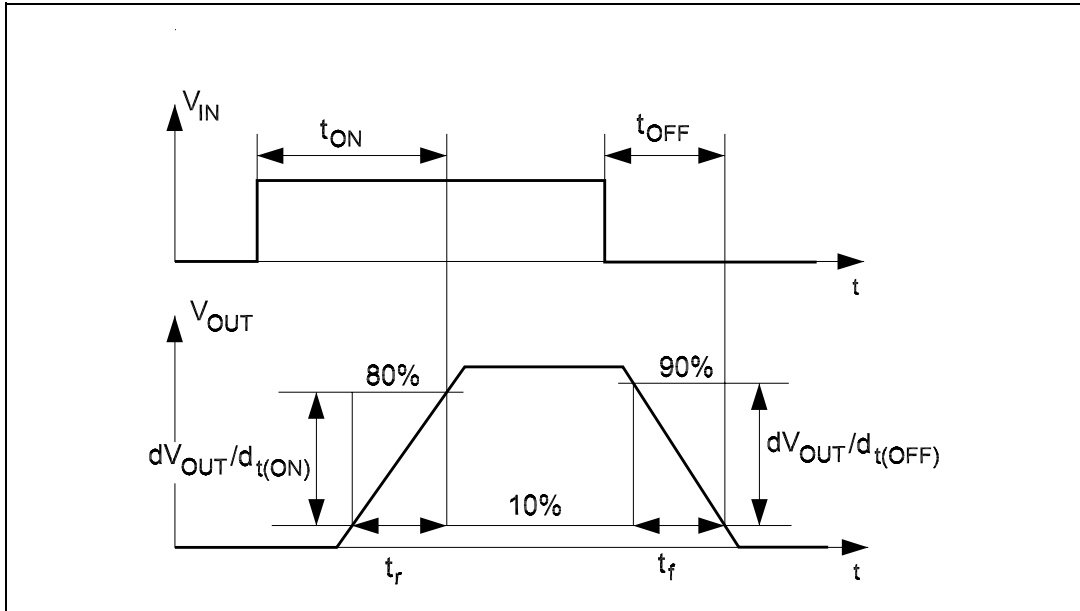

Figure 7. V_{CC} turn-ON

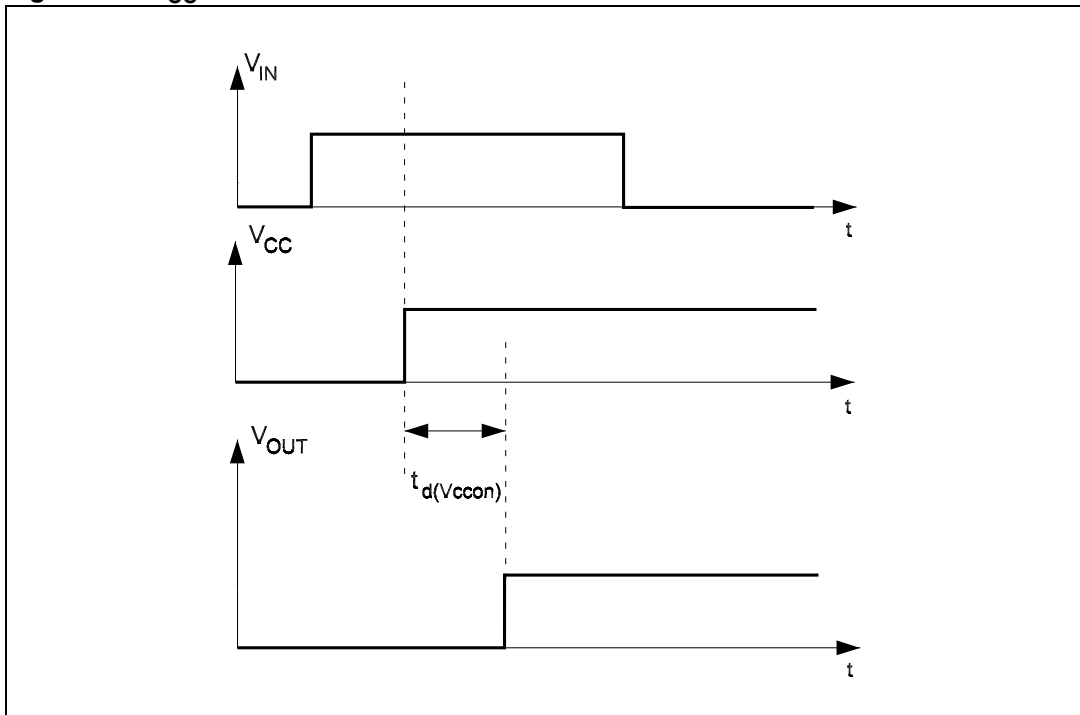

Figure 8. Waveforms

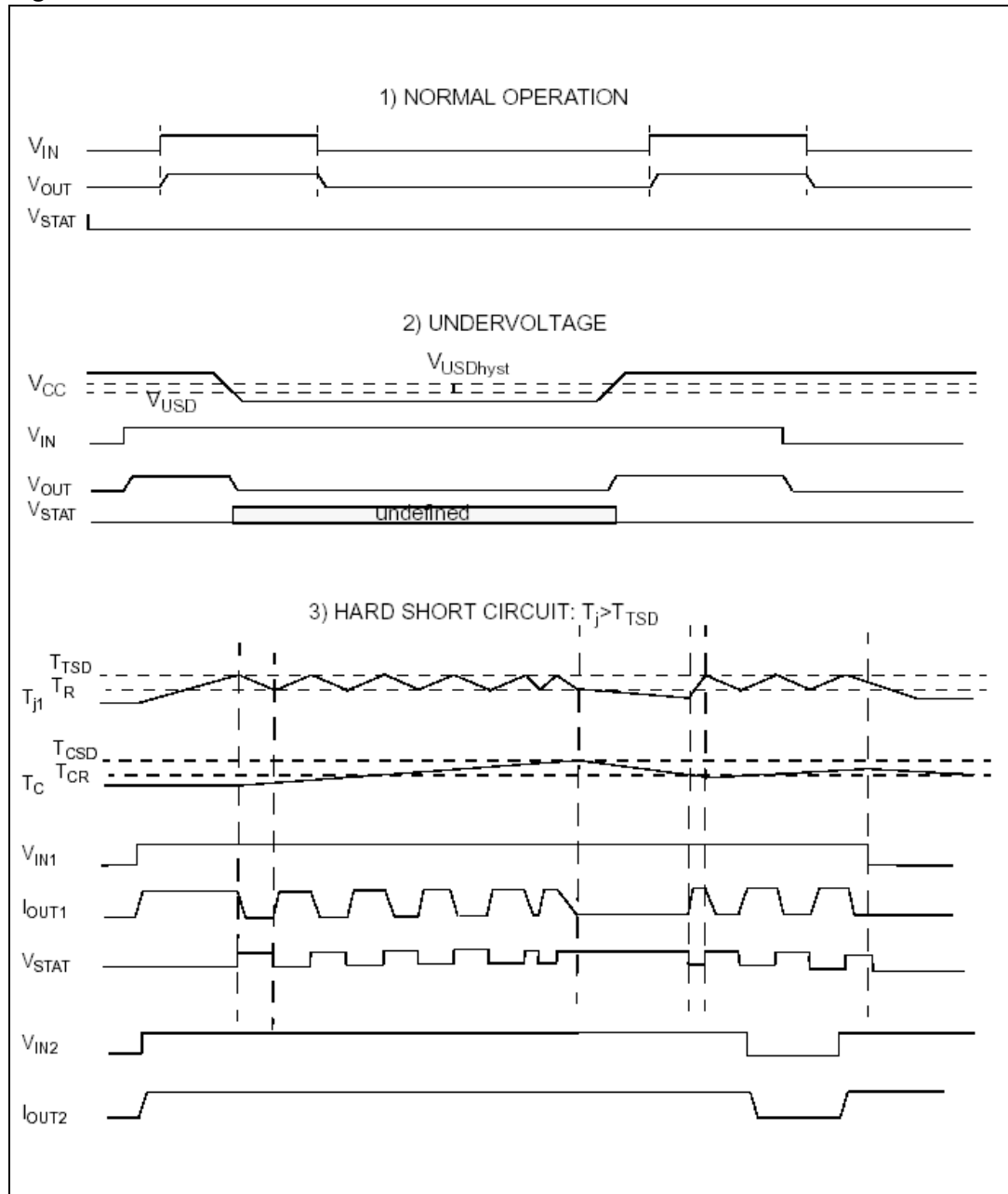
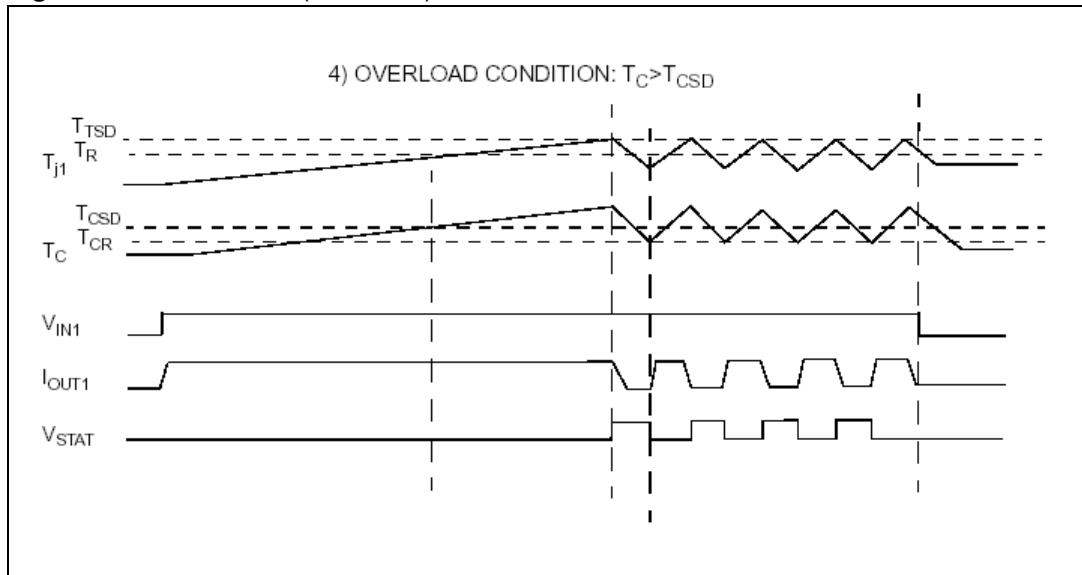

Figure 8. Waveforms (continued)



6 Reverse polarity protection

A schematic solution to protect the IC against a reverse polarity condition is proposed.

This schematic is effective with any type of load connected to the outputs of the IC.

The R_{GND} resistor value can be selected according to the following conditions to be met:

1. $R_{GND} \leq 600 \text{ mV} / (I_S \text{ in ON state max})$.
2. $R_{GND} \geq (-V_{CC}) / (-I_{GND})$

where $-I_{GND}$ is the DC reverse ground pin current and can be found in the absolute maximum rating section of the device datasheet.

The power dissipation associated to R_{GND} during reverse polarity condition is:

$$PD = (-V_{CC})^2 / R_{GND}$$

This resistor can be shared by several different ICs. In such case I_S value on formula (1) is the sum of the maximum ON-state currents of the different devices.

Please note that if the microprocessor ground and the device ground are separated then the voltage drop across the R_{GND} (given by I_S in ON state max * R_{GND}) produce a difference between the generated input level and the IC input signal level. This voltage drop will vary depending on how many devices are ON in the case of several high side switches sharing the same R_{GND} .

Figure 9. Reverse polarity protection

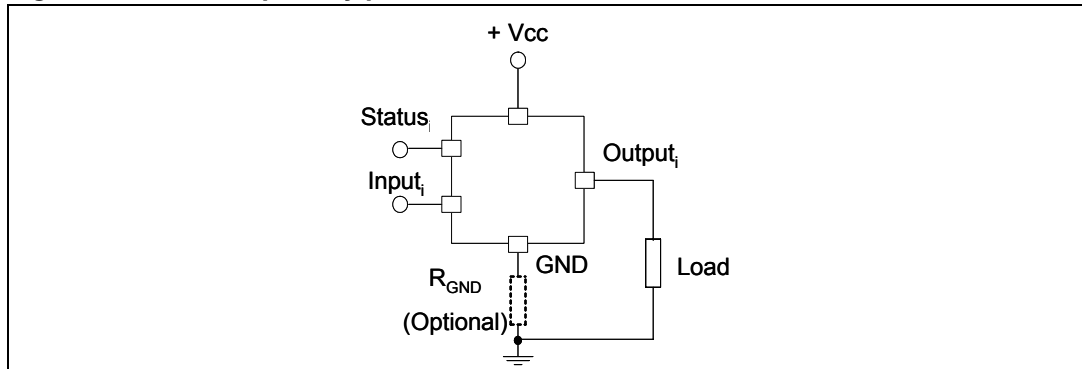

7 Package mechanical data

In order to meet environmental requirements, ST offers these devices in ECOPACK® packages. These packages have a lead-free second level interconnect. The category of second Level Interconnect is marked on the package and on the inner box label, in compliance with JEDEC Standard JESD97. The maximum ratings related to soldering conditions are also marked on the inner box label. ECOPACK is an ST trademark. ECOPACK specifications are available at: www.st.com.

Table 10. PowerSO-36 mechanical data

| Dim. | mm | | | inch | | |
|--------|-------|-------|-------|-------|-------|--------|
| | Min. | Typ. | Max. | Min. | Typ. | Max. |
| A | | | 3.60 | | | 0.1417 |
| a1 | 0.10 | | 0.30 | 0.003 | | 0.0118 |
| a2 | | | 3.30 | | | 0.1299 |
| a3 | 0 | | 0.10 | 0 | | 0.0039 |
| b | 0.22 | | 0.38 | 0.008 | | 0.0150 |
| c | 0.23 | | 0.32 | 0.009 | | 0.0126 |
| D (1) | 15.80 | | 16.00 | 0.622 | | 0.6299 |
| D1 | 9.40 | | 9.80 | 0.370 | | 0.3858 |
| E | 13.90 | | 14.50 | 0.547 | | 0.5709 |
| E1 (1) | 10.90 | | 11.10 | 0.429 | | 0.4370 |
| E2 | | | 2.90 | | | 0.1142 |
| E3 | 5.8 | | 6.2 | 0.228 | | 0.2441 |
| e | | 0.65 | | | 0.025 | |
| e3 | | 11.05 | | | 0.435 | |
| G | 0 | | 0.10 | 0.000 | | 0.0039 |
| H | 15.50 | | 15.90 | 0.610 | | 0.6260 |
| h | | | 1.10 | | | 0.0433 |
| L | 0.80 | | 1.10 | 0.031 | | 0.0433 |
| N | | | 10° | | | 10° |
| S | 0° | | 8° | 0° | | 8° |

Figure 10. PowerSO-36 drawings

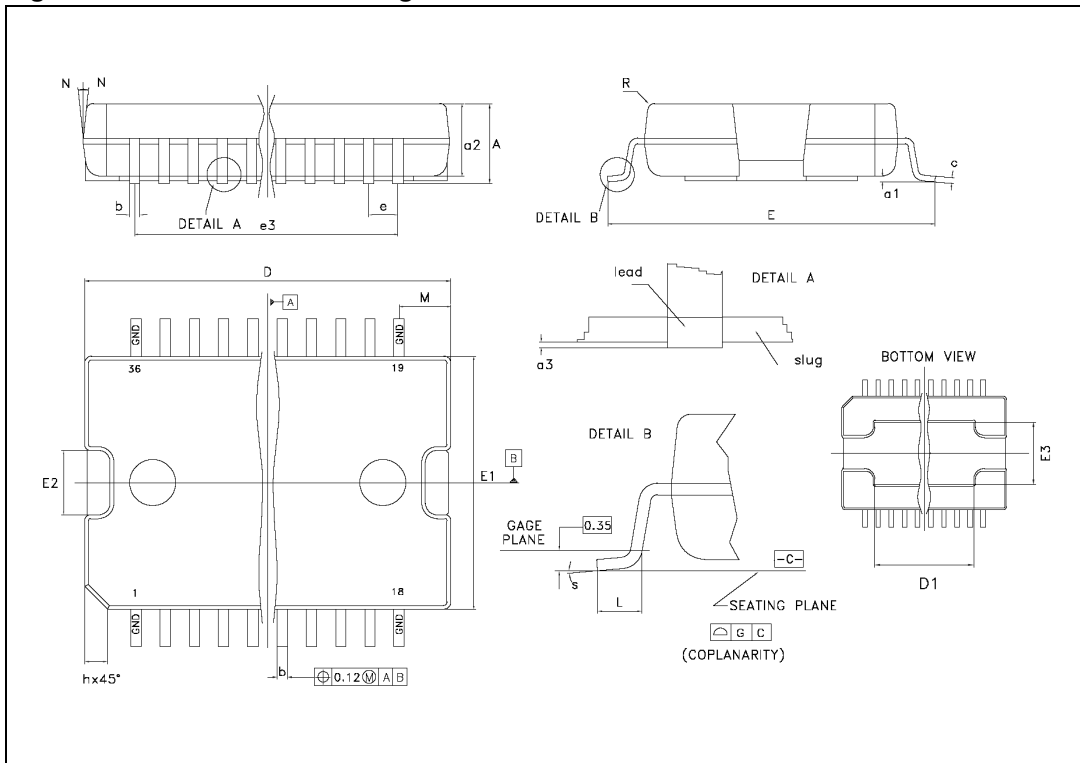
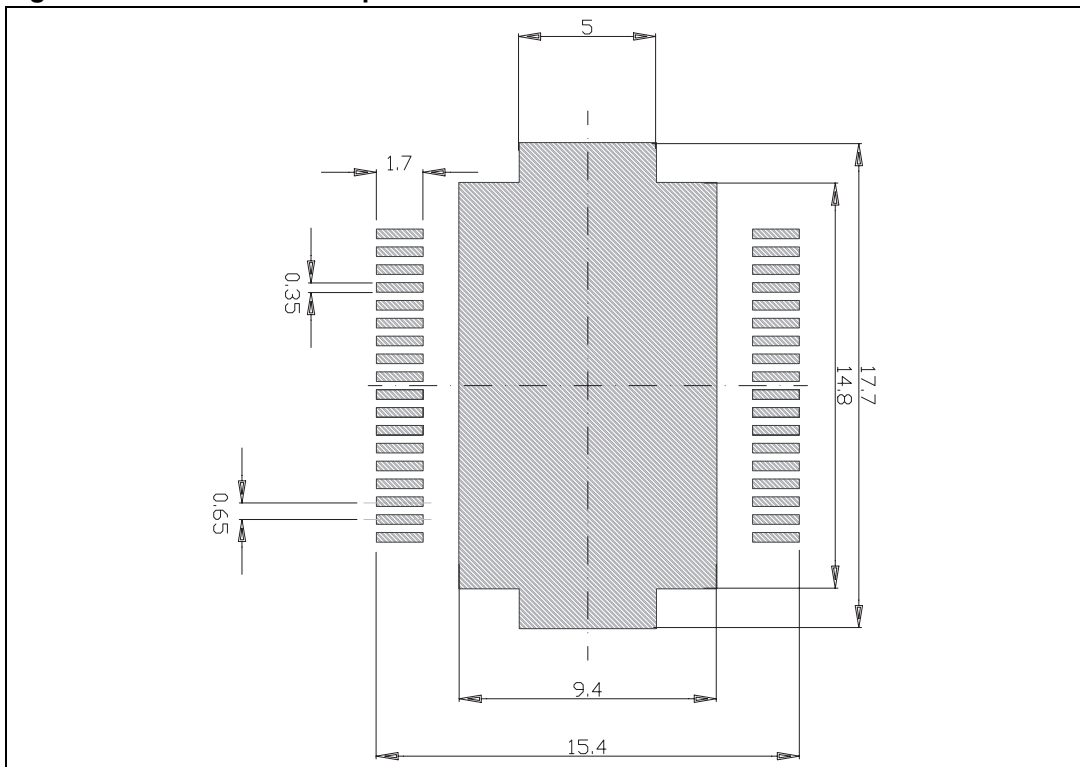

Figure 11. PowerSO-36 footprint



8 Order codes

Table 11. Order codes

| Order codes | Package | Packaging |
|--------------------|----------------|------------------|
| VN808-E | PowerSO-36 | Tube |
| VN808TR-E | PowerSO-36 | Tape and reel |

9 Revision history

Table 12. Document revision history

| Date | Revision | Changes |
|-------------|----------|--|
| 13-Sep-2005 | 1 | Initial release |
| 1-Mar-2007 | 2 | Document reformatted |
| 12-Mar-2007 | 3 | Typo in <i>Figure 3</i> . |
| 26-Mar-2007 | 4 | Typo note <i>Table 2</i> . |
| 07-Jul-2008 | 5 | Added: <i>Section 6 on page 13</i> |
| 04-Aug-2008 | 6 | Added: <i>Figure 11: PowerSO-36 footprint on page 15</i> |

Please Read Carefully:

Information in this document is provided solely in connection with ST products. STMicroelectronics NV and its subsidiaries ("ST") reserve the right to make changes, corrections, modifications or improvements, to this document, and the products and services described herein at any time, without notice.

All ST products are sold pursuant to ST's terms and conditions of sale.

Purchasers are solely responsible for the choice, selection and use of the ST products and services described herein, and ST assumes no liability whatsoever relating to the choice, selection or use of the ST products and services described herein.

No license, express or implied, by estoppel or otherwise, to any intellectual property rights is granted under this document. If any part of this document refers to any third party products or services it shall not be deemed a license grant by ST for the use of such third party products or services, or any intellectual property contained therein or considered as a warranty covering the use in any manner whatsoever of such third party products or services or any intellectual property contained therein.

UNLESS OTHERWISE SET FORTH IN ST'S TERMS AND CONDITIONS OF SALE ST DISCLAIMS ANY EXPRESS OR IMPLIED WARRANTY WITH RESPECT TO THE USE AND/OR SALE OF ST PRODUCTS INCLUDING WITHOUT LIMITATION IMPLIED WARRANTIES OF MERCHANTABILITY, FITNESS FOR A PARTICULAR PURPOSE (AND THEIR EQUIVALENTS UNDER THE LAWS OF ANY JURISDICTION), OR INFRINGEMENT OF ANY PATENT, COPYRIGHT OR OTHER INTELLECTUAL PROPERTY RIGHT.

UNLESS EXPRESSLY APPROVED IN WRITING BY AN AUTHORIZED ST REPRESENTATIVE, ST PRODUCTS ARE NOT RECOMMENDED, AUTHORIZED OR WARRANTED FOR USE IN MILITARY, AIR CRAFT, SPACE, LIFE SAVING, OR LIFE SUSTAINING APPLICATIONS, NOR IN PRODUCTS OR SYSTEMS WHERE FAILURE OR MALFUNCTION MAY RESULT IN PERSONAL INJURY, DEATH, OR SEVERE PROPERTY OR ENVIRONMENTAL DAMAGE. ST PRODUCTS WHICH ARE NOT SPECIFIED AS "AUTOMOTIVE GRADE" MAY ONLY BE USED IN AUTOMOTIVE APPLICATIONS AT USER'S OWN RISK.

Resale of ST products with provisions different from the statements and/or technical features set forth in this document shall immediately void any warranty granted by ST for the ST product or service described herein and shall not create or extend in any manner whatsoever, any liability of ST.

ST and the ST logo are trademarks or registered trademarks of ST in various countries.

Information in this document supersedes and replaces all information previously supplied.

The ST logo is a registered trademark of STMicroelectronics. All other names are the property of their respective owners.

© 2008 STMicroelectronics - All rights reserved

STMicroelectronics group of companies

Australia - Belgium - Brazil - Canada - China - Czech Republic - Finland - France - Germany - Hong Kong - India - Israel - Italy - Japan - Malaysia - Malta - Morocco - Singapore - Spain - Sweden - Switzerland - United Kingdom - United States of America

www.st.com